

# ADC-44 Conveyor by

HIGH or LOW temp the choice is yours...

A High Capacity **ENERGY SAVING**, self-purging stage conveyor...

- 244 Racks per Hour
- Operates **ONLY** when Racks are Inserted
- **Unrivaled** cleaning ability
- **Dual** rinsing system
- **User Friendly** conveyor
- Uses as little as **.49 gallons** per load

- flips open, snaps shut
- quick fast clearing of spray arms
- shortens the cleaning process & eliminates down time

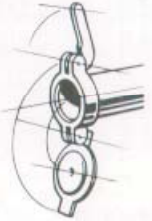

Captive end caps

## Water Curtain Rinseability

- activates prior to final rinse
- initiates the rinsing process and acts as a shield

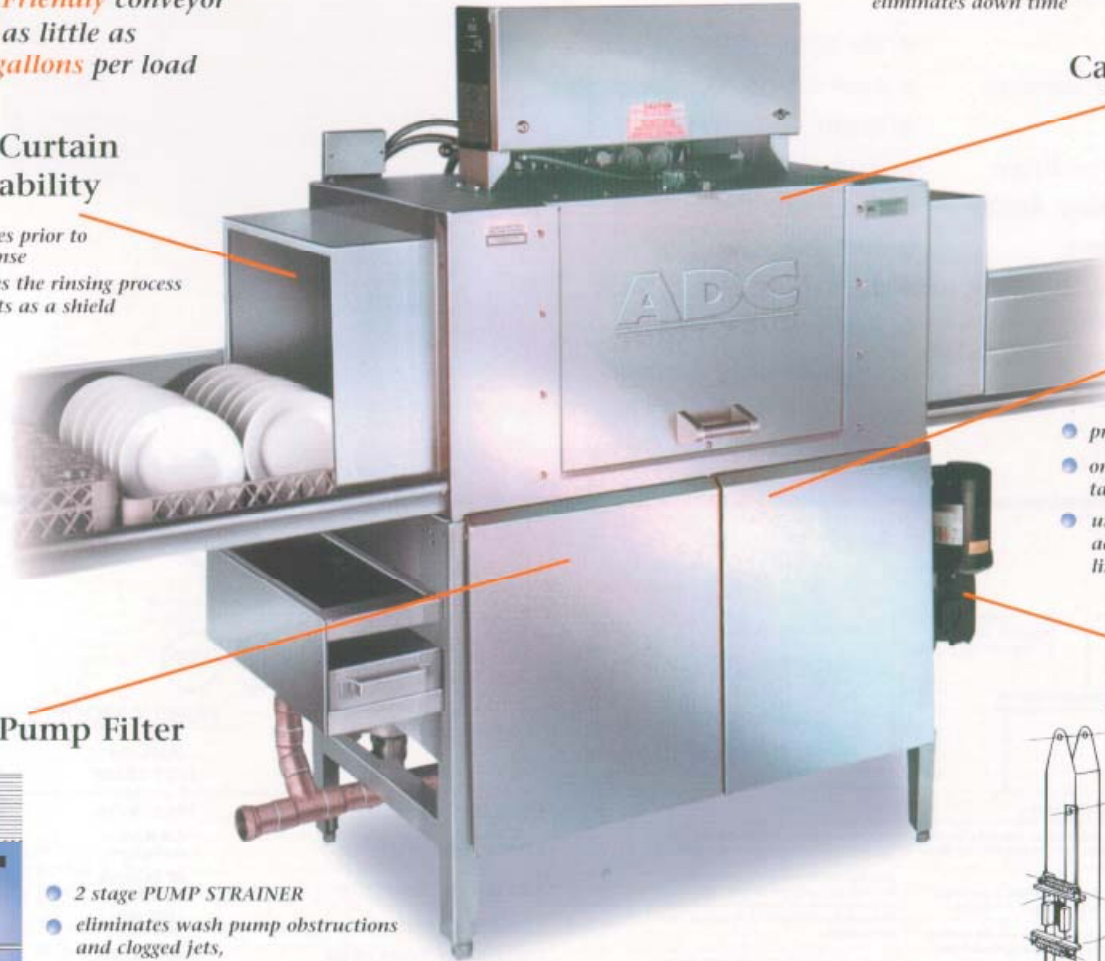

## Dual - Fail Safe Heater Control

- precise water control mechanism
- only allows heaters to operate when tank is full
- unaffected by heavy soil, water action, strong chemicals and lime build up

## Fail-Safe Conveyor System

- slip clutch design - stops rack movement
- once removed operation easily resumes
- eliminates damaged racks

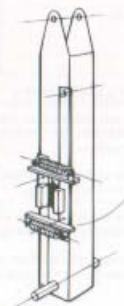

## Drain Pump Filter



- 2 stage PUMP STRAINER
- eliminates wash pump obstructions and clogged jets,
- functions as drain stopper

**Quality & Reliability...** As tempting as it may be, a Conveyor cannot be built just to perform...  
*It must be built to Survive.*

At American Dish Service, Quality People, Designs, and Products have been the foundation of our organization for over **45 years**.

[www.americandish.com](http://www.americandish.com)



**American Dish Service**  
Manufacturers of Ware Washing Equipment

900 Blake Street Edwardsville, KS 66111-3820 Toll Free (800) 922-2178 Phone (913) 422-3700 Fax (913) 422-6630

# ADC-44 Conveyor

All these features are Standard on the ADC-44. While other manufacturers may offer these same features as Add-Ons... at American Dish our machines are COMPLETE & READY TO RUN.

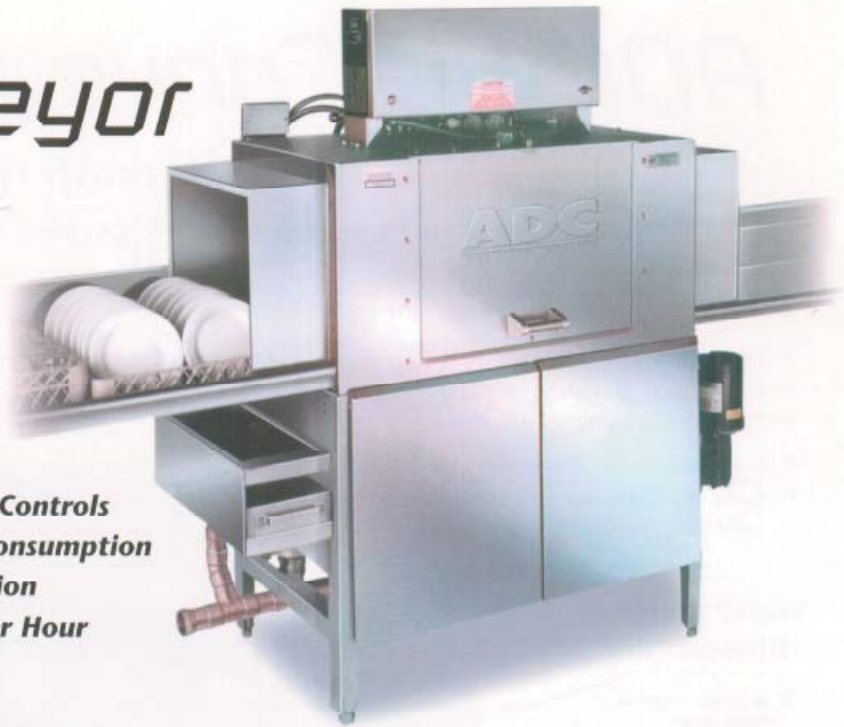

- Auto-Fill
- Energy Saving Stage Washer
- No Circuit Boards
- Rack Saving Conveyor Drive
- 360 Sq. in. of Washing Action
- High Capacity Heaters
- Wide Opening Access Doors with Safety Interlock
- Skirted Motor Compartment
- Heavy Stainless Steel Const.
- No Operator Controls
- Low Water Consumption
- Quiet Operation
- 244 Racks per Hour
- Auto Cut-Off
- Self-Purging
- 11 Gallon Wash Tank
- 3HP Wash Pump
- Dual Rinsing System

Effective 5/28/02

## RIGHT FEED (W/O VENT OPTION)

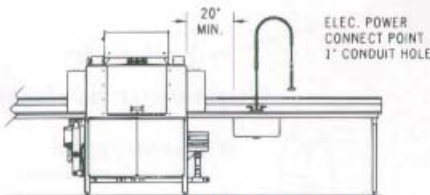

## TOP VIEW OF LEFT FEED

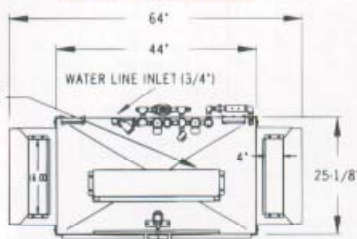

## IMPORTANT NOTES

Both clean and soiled tables are to be bolted to the dishmachine with the 1/4-20x1/2" bolts and nuts provided.

Leaks cause potential problems in electrical and mechanical areas under the machine.

Quick drains (table scuppers) are not compatible with stage type conveyor dishmachines.

Scrap sinks shall be no closer than 20" minimum from the dishmachine end of table.

The clean exit table should be at least 72" straight for efficient conveyor operation.

Electrical and plumbing connections should be made by a qualified Service Person who will comply with all available federal, state, and local Health, Electrical, Plumbing, and Safety codes.

Manufacturer reserves the right to modify these specifications in compliance with regulatory agencies and manufacturing expediency.

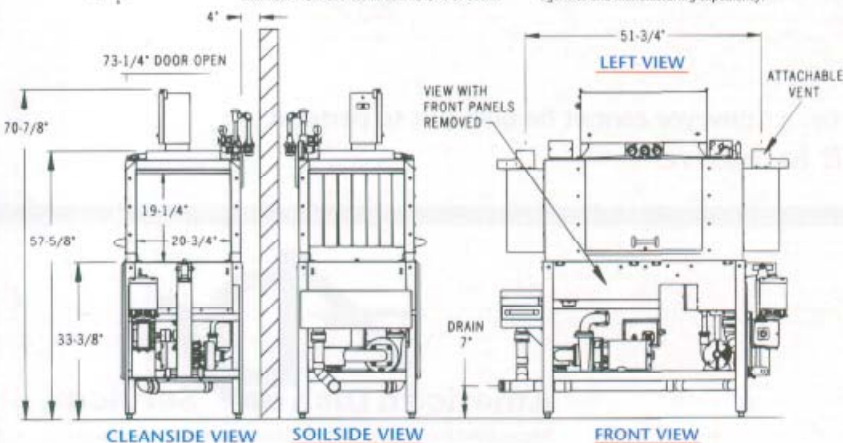

## ADC-44

## FAMILY MODELS (left or right feed)

	ADC-44 HOT TEMP	ADC-44 CHEMICAL
NSF RATED CAPACITY (racks/hour)	244 racks/hr.	244 racks/hr.
CONVEYOR SPEED	6.8 ft/min (2.07 meters)	6.8 ft/min (2.07 meters)
WATER CONSUMPTION	.49 gal/rack (1.8 liters)	.49 gal/rack (1.8 liters)
TOTAL GALLONS PER HOUR	120 gph (454.2 liters)	120 gph (454.2 liters)
FINAL RINSE TEMP (20 psi)	180°F (82.2 C)	120°F (48.8 C)
SANITIZER	180° WATER	50ppm CHLORINE
ELECTRICAL POWER SUPPLY	208 / 240V, 3 PH, 60 AMP, 60 HZ (Requires clean circuit) 1PH, 50/60 AMP, 60 HZ (Single Phase requires one(1) 50 amp service with neutral and one(1) 60 amp service)	
MOTOR RATINGS	3HP WASH, 1/3HP RINSE 1/3HP CONVEYOR	
HEATER RATINGS	12KW WASH, 2.25KW RINSE	
RACK SIZE	STANDARD 19.75" x 19.75" (50.2 x 50.2 cm)	
ACCESS DOOR CLEARANCE	15" TALL x 24.5" WIDE (38.1 x 62.2 cm)	
RACK CLEARANCE (Through machine)	19.25" x 20.75" (48.9 x 52.7 cm)	
WATER INLET	(3/4") F.P.T.	
DRAIN SIZE	(2") F.P.T. (or 2" off floor to center)	
HEIGHT (with door open)	73.25" (186 cm)	
WIDTH (overall)	64" (162.5 cm)	
WIDTH, TABLE TO TABLE	44" (111.7 cm)	
DEPTH	29" (73.7 cm)	
SHIPPING WEIGHT	760 lbs (344.7 kg)	
SHIPPING VOLUME (crated)	121.6 CU. ft. (3.4 cu meters)	

ADS has built a strong history based on Customer Service, Quality and Reliability. A Commitment to Excellence is the driving force behind American Dish Service.